



15PPM BILGE SEPARATOR

IMO Resolution MEPC.107(49) Approved Type

SEWAGE TREATMENT PLANT

IMO Resolution MEPC.159(55)

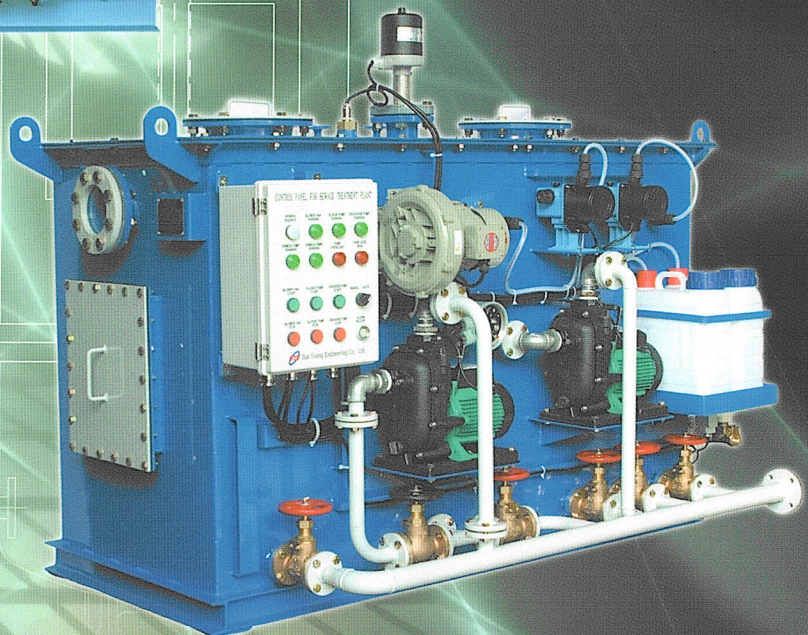
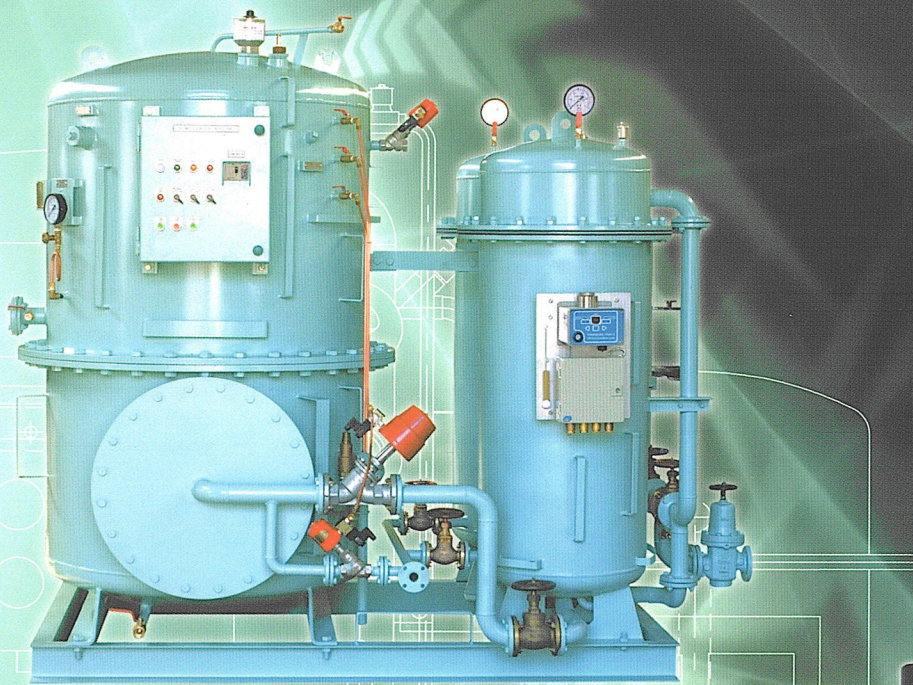

HAN YOUNG ENGINEERING CO., LTD.



COMPANY INTRODUCTION

Our products are various 15ppm Bilge Separator from Min. 0.2m³/hr to Max. 10.0m³/hr with type approval certificates issued by Korean Government and C.E in accordance with IMO Resolution MEPC 107(49).

Our products are various Sewage treatment from Min10persons to MAX 125persons with type approval Certificates issued Korean Government and C. E. in accordance with IMO Resolution MEPC 159(55).

COMPANY HISTORY

- 1 Jul. 1982 Established at Incheon.
- 2 Aug. 1983 founded factory at Paju Kyonggi-Do.
- 3 Aug. 1983 Technical tie-up with Koe Separator & Taiho Industry Technic.
- 4 Sep. 1983 Registered the shipping Industry Related Company.
- 5 Sep. 1983 Developed Life Raft and Equipment.
- 6 Jan. 1989 Moved factory to Incheon.
- 7 Sep. 1994 Obtained Type Approval Certificated of 6 kind oil filtering Equipment in accordance with part 1 fo the Annex to resolution MEPC. 60(33)
- 8 Jul. 1995 Developed Pre-Treatment Device.
- 9 Nov. 1999 Obtained Ec Type-Examination Certificated verifying the quality is acceptable by DNV(OS Type series 8 sets)
- 10 Dec. 1999 Obtained ISO-9001 Certificate of approval for the Oil Filtering Equipment, Life raft and Emergency Ration.
- 11 Jan. 2000 Moved factory the Kimhae, Kyong Nam
- 12 Jan. 2000 Granted maintenance-Business for life raft.
Granted Storage for Explosives.
- 13 Feb. 2001 Technical License contact with Semco, Denmark for Water Mist System.
- 14 Jul. 2001 Developed Foam, Dry Powder and Co2 Fire Extinguishers.
- 15 Jan. 2005 Acquired EC Type Certificated for 15ppm bilge separator in accordance with IMO Resolution MEPC. 107(49) from DNV. (HYN00000 : series type 8 sets)
- 16 Apl. 2006 Acquired EC Type Certificated for 15ppm Bilge separator in accordance with IMO Resolution MEPC. 107(49) from DNV. (HYN00001) : series type 8 sets)
- 17 Sep. 2007 Developed Sewage Treatment Plant.

PRODUCTS

- **15ppm Bilge Separator** (IMO-MEPC 107(49) EC-Type Approved / MED-CERT)
- **Sewage Treatment Plant** in accordance With IMO Resolution MEPC159(55)
- 15ppm Bilge alarm(IMO-MEPC 107(49) Type Approved)
- Coalescer filter, NF filter cortridge with Motor / Pump: Mono & Piston type
- Hot water calorifier
- Pre-treatment unit for 15ppm Bilge Separator
- Spare parts, repair & after service

15PPM BILGE SEPARATOR

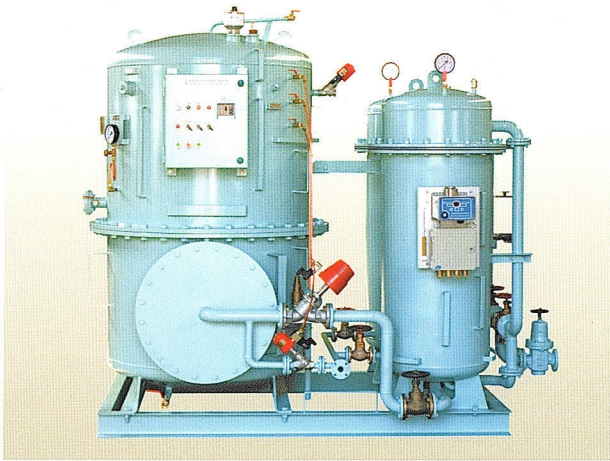

Features

To Extend the operation life of the demulsifier an automatic bypass is fitted to the separating system. The 15ppm oil content measuring device periodically checks the water quality of the HYN series separator and if below 15ppm, the demulsifier is bypassed until the 15ppm alarm is activated. This process control guarantees a considerable prolonged life cycle of the adsorber elements.

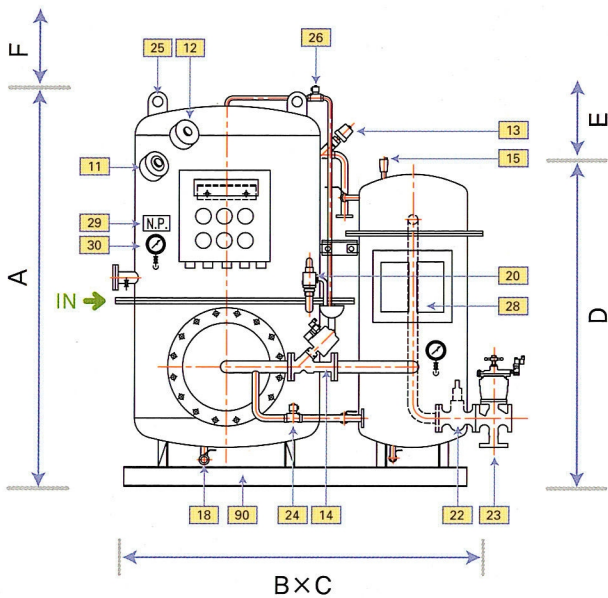

Specifications

11	Heating device	23	3way cylinder valve
12	Oil Detector	24	Backwashing valve
13	Oil out valve	25	Eye plate
14	Return valve	26	Escape vent
15	Air vent	28	15ppm bilge alarm
18	Drain	29	Name plate
20	Safety valve	30	Pressure gauge
22	Regulating valve	90	Common bed

LAYOUT DIMENSIONS

MODEL	CAPACITY (m ³ /h)	A (mm)	B (mm)	C (mm)	D (mm)	E (mm)	F (mm)	INLET (A)	OUTLET (A)	OILOUT (A)	WEIGHT(kg)	
											EMPTY	FULL
HYN00201	0.2	850	400	250	—	300	—	20	15	15	98	165
HYN00301	0.3	850	500	400	—	300	—	20	20	15	120	190
HYN00501	0.5	1000	600	500	—	300	—	20	20	15	140	280
HYN01001	1.0	1400	900	1000	1200	100	300	25	25	20	290	650
HYN02001	2.0	1900	1200	1400	1650	100	300	32	25	20	480	1250
HYN03001	3.0	1900	1300	1500	1650	100	300	40	32	25	580	1450
HYN05001	5.0	1950	1900	1700	1700	100	300	50	40	25	800	2300
HYN10001	10.0	1950	2400	1750	1700	100	300	50	50	25	1200	3400

Piping & Installation (Application: HYN 00201, 00301, 00501 Type)

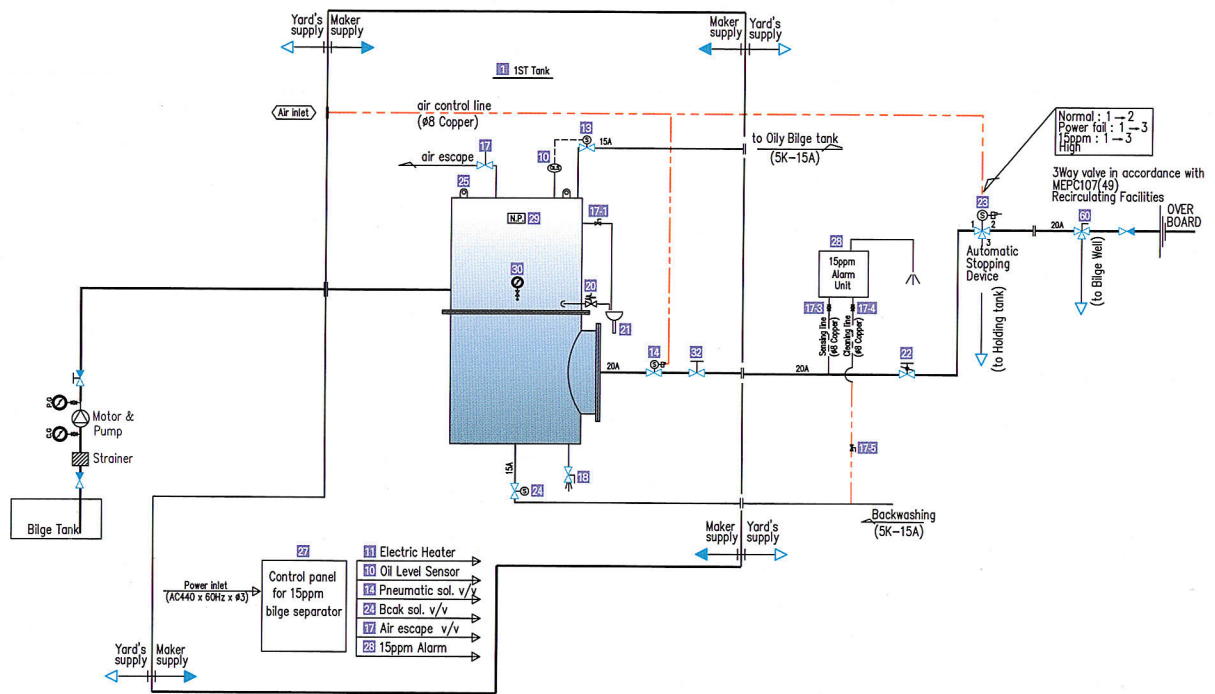

Piping & Installation (Application: HYN 02001, 03001, 05001, 10001 Type)

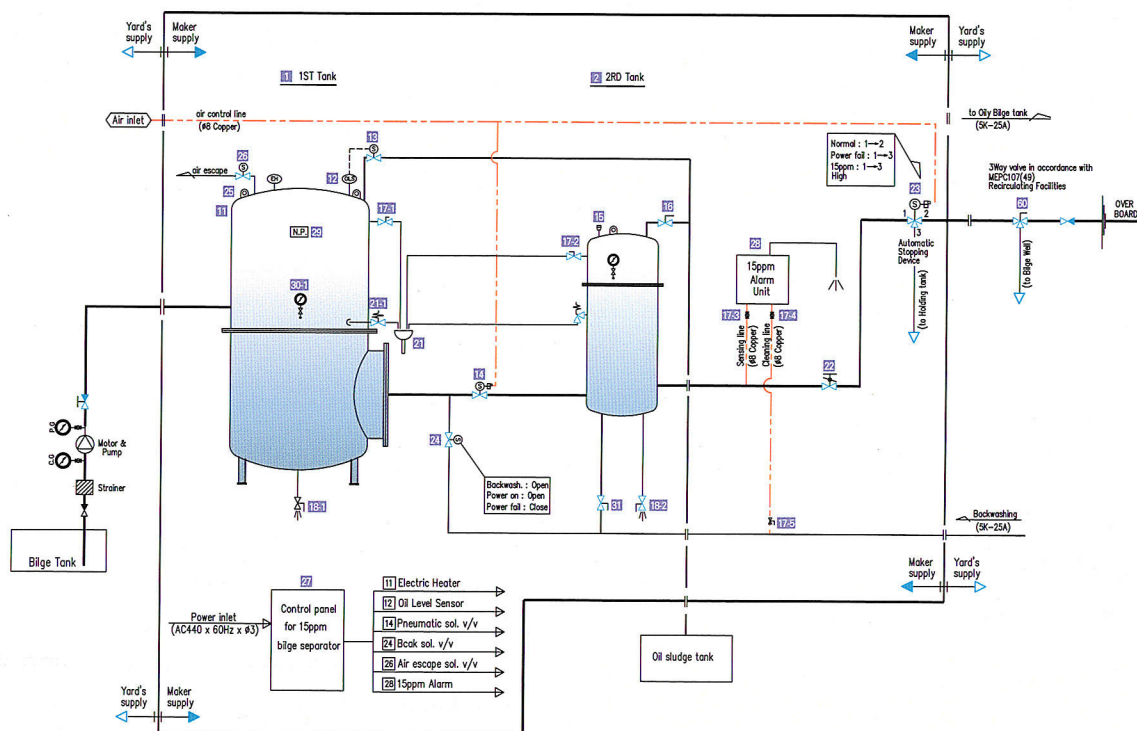

Description of Process for 15ppm bilge Separator (Application: HYN 00201, 00301,00501 Type)

Fig. 1 Oily water separation

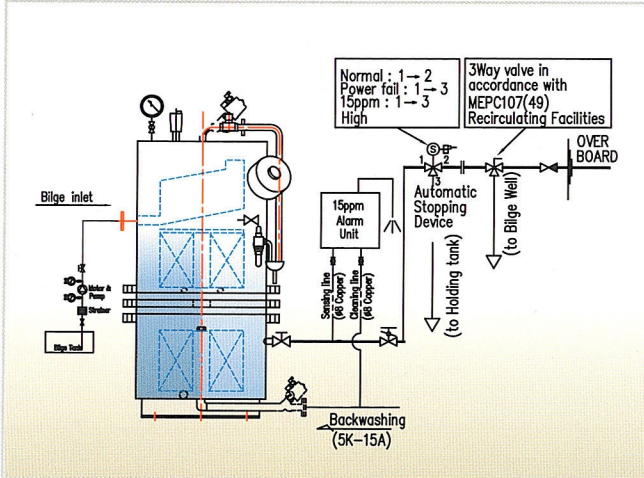

Fig. 1 Separation of oil and water

15PPM Bilge Separator separates oil and water by difference of their specific gravity.

The oily water is commenced to be separated when passing 4-way distributing device, and the floated and accumulated oil are collecting into the upper part of 1st chamber of the 1st vessel and also the remains including minute oil particles of oily water passes through the Pallring & Urethane Coalescer equipped in the 2nd chamber of the 1st vessel. During this process, the size of oily particle become great and floating speed of the particles are increased, thus the oil floats easily. As the emulsified oil is removed by Coalescer equipped in the 3rd chamber of the 1st vessel and 2nd vessel (Emulsion Treatment Unit), and then water is discharged under the condition of below 15ppm (or 5ppm) of oil density.

Fig. 2 Oil Discharge

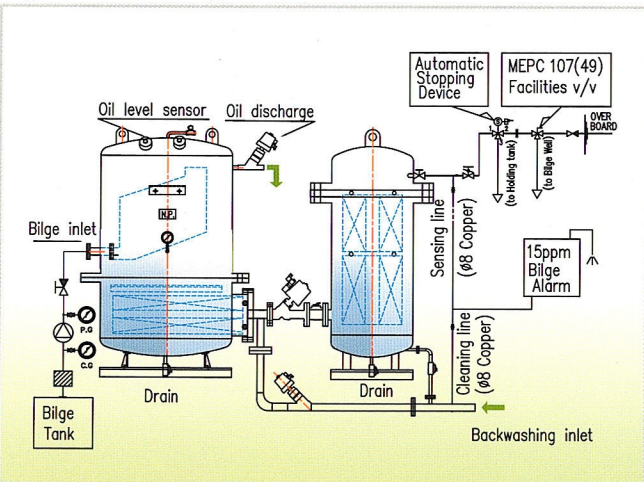

Fig. 2 Oil Discharge

When the collected oil in the upper part of the 1st chamber is detected by the oil level detector, the oil discharging valves is opened and then oil is discharged automatically by the Backwashing system.

Fig. 3 Backwashing

(1st chamber of the 1st vessel)

When the oil level detector detects oil, the bilge pump is stopped and the oil discharge valve is opened and direction 2-way backwashing valve is changed for backwashing at the same time. The coalescer filter in the 3rd chamber and Pallring & Urethane Coalescer in the 2nd Chamber are cleaned by Backwashing water automatically, and the floating objects with oil are discharged .

(2nd vessel (Emulsion Treatment Unit))

The emulsified oil is removed by the Coalescer and the equipment is cleaned by Backwashing after opening the Air vent valve, with manual Backwashing valve thus the performance and efficiency of the system are improved.

Fig. 3 Backwashing

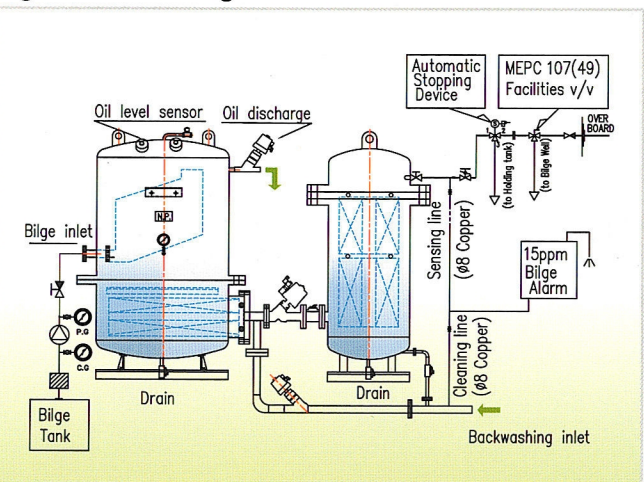

BILGE PUMP(Piston type) & SLUDGE PUMP(Mono type)

Layout Arrangement

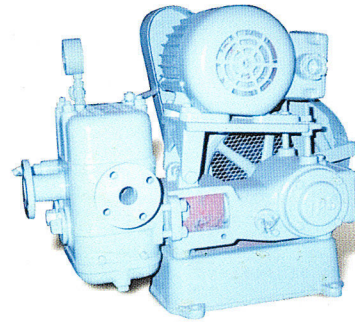
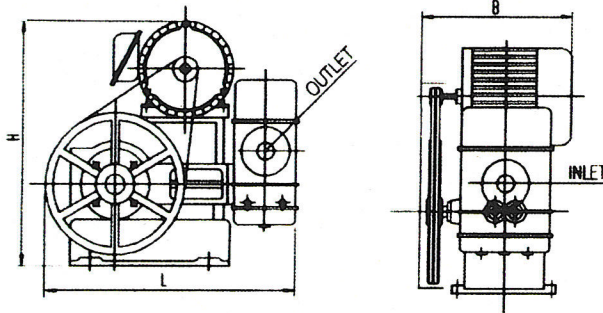

Layout Dimensions

MODEL	UNIT	1015C	1015	1015B	101A	101B	101	102	103
CAPACITY	m ³ /hr	0.15	0.2	0.3	0.5	1.0	2.0	5.0	10.0
MOTOR	KW	0.4×4P	0.4×4P	0.4×4P	0.4×4P	0.4×4P	0.75×4P	1.5×4P	2.2×4P
PUMP	R,P,M	420	420	420	280	280	280	220	240
L	mm	510	510	510	450	450	450	745	770
B	mm	300	300	300	284	284	284	410	430
H	mm	420	420	420	480	480	480	570	570
IN/OUTLET	5K	15A	15A	20A	20A	25A	40A	40A	50A
WEIGHT	KG	39	39	39	66	66	75	145	175

PRE-TREATMENT

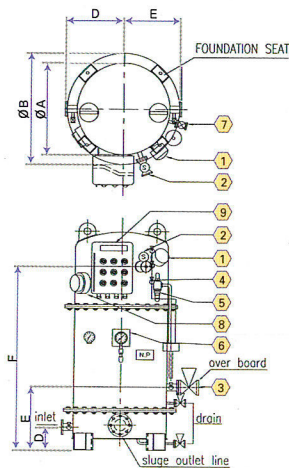
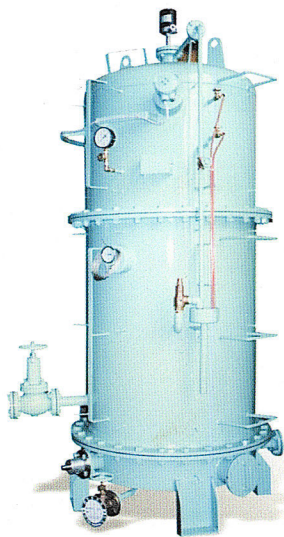

Specifications

NO	Description	Contents
1	level sensor	LSOS(LSC-80)
2	2way air v/v	AP-25/SV210
3	discharge	25A, 40A, 50A
4	test v/v	PT1/4", 3/8"
5	safety v/v	0-7kg/cm ²
6	press, gauge	0-6kg/cm ²
7	drain v/v	25A, 40A, 50A
8	heating system	steam/electric
9	control panel	standard

Layout Dimensions

	TYPE(HYPUS)			
	1.0m ³ /hr	2.0m ³ /hr	5.0m ³ /hr	10.0m ³ /hr
ΦA	459	659	809	909
ΦB	540	780	930	1040
C	310	500	570	630
D	280	450	480	530
E	200	450	350	530
F	920	550	1550	1650
H	1000	1600	1750	1850
Dry weight	210	550	580	610

15PPM BILGE ALARM

Type OMD-2005

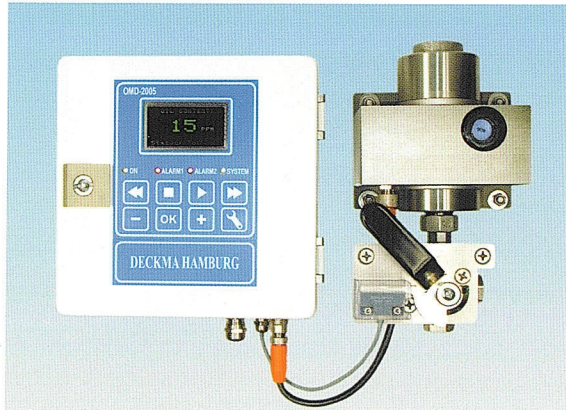

SMART CELL-BILGE



The oily water separating system is equipped with the 15ppm Bilge alarm device OMD & FOCAS-1800 type tested and approved in accordance with IMO Resolution MEPC. 107(49). The 3-way cock for flushing is fitted with a contact to ensure that during flushing of the alarm device, and the 3-way diverting valve is in

recirculation mode (automatic stopping device).

According to IMO Resolution MEPC. 107(49) a 3-way valve is installed downstream of the oily water separator in the overboard line to recirculate the water to the bilge whenever required during port state control.

Specifications

Range : 0–30ppm, Trend up to 50ppm	Output signal : 0–20mA for 0–30ppm
Accuracy : According IMO MEPC. 107(49)	Sample water pressure : 0.1–10 bar
Linearity : Up to 30ppm better than $\pm 2\%$	Sample Flow : Approx $\times 0.1-4 \text{ l/min}$
Display : Gree Graphic Display	Alarm Indication : Red LED's
Power supply : 24V AC or DC	Size (over all) : $360 \times 240 \times 100 \text{ (mm)}$
Consumption : 15VA	Degree of protection : 1P 44
Alarm points 1+2 : Adjustable between 1–15	Weight : $7.3\text{kg} \pm 2$
System fault Alarm : Red LED	Pip fitting : R1/4" Female

Piping & installation

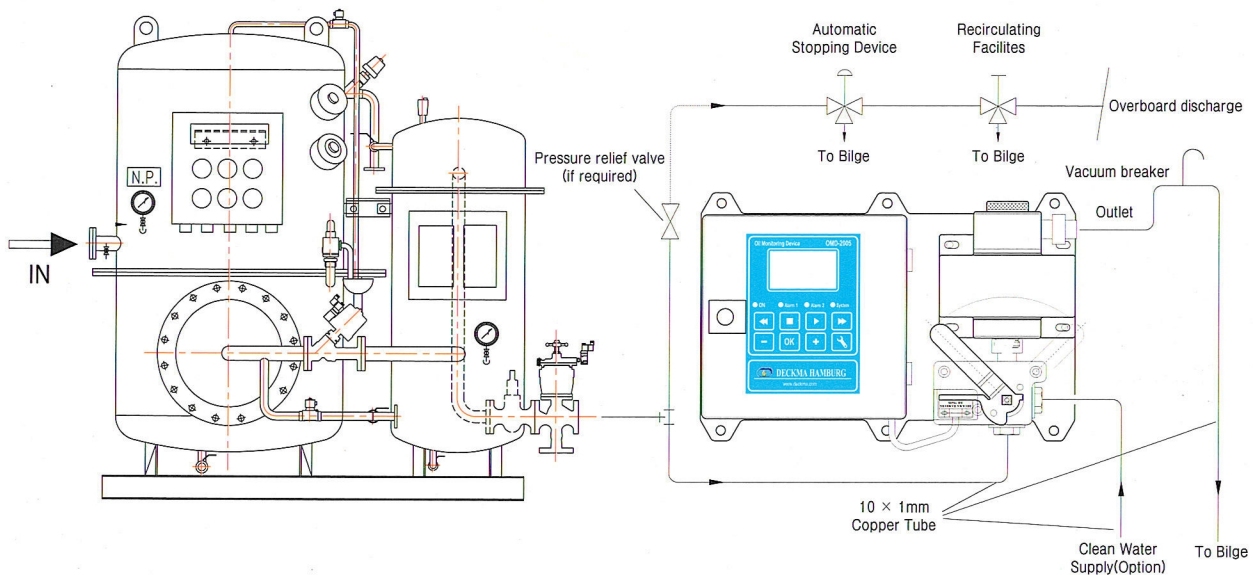

SEWAGE TREATMENT PLANT

IMO Resolution MEPC 159(55)

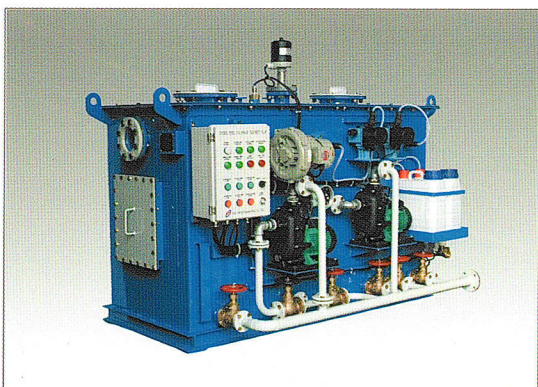

HAN YOUNG ENGINEERING CO.,Ltd has met the challenge of protecting the environment by developing a new advanced wastewater treatment process based on biological degradation and membrane separation. This process produces the highest quality discharge without requiring any addition or generation of chemicals that are hazardous to the environment or ship operation. Han young contracted industry–university cooperation in Korea Maritime University.

Efficiency of purification

The Han young system applies to ships and marine structures the process of biological waste water treatment in combination with submerged low–pressure micro–filtration membranes, which act as barriers to the activated sludge as well as to bacteria and viruses. Accordingly the Han young technology purifies water – without any final clarification or any additional disinfection – that meets the quality standards of as well IMO/MARPOL, HELCOM, German Federal Law Gazettes No. II, page 1378 and No. I, page 1221, USCG, US Federal Law Gazette No. 40, section 133, Australian ADNOC and Australian Federal Environmental agency as Alaska agreement.

Effluent Constituent	IMO Resolution MEPC.2(VI)	USCE 33CFR 159	Tertiary Treatment proposed by some local Australian Agencies	NATO proposal suggested as achievable by 2005	USA 22CFR 159 Alaskan waters cruise ships	Han young tested
BOD ₅	50mg/L	Not required	20mg/L	30mg/L	30mg/L	4.1mg/L
COD				300mg/L		6.5mg/L
Chlorine	As low as possible	Not required		Not permitted	10mg/L	0mg/L
Total Suspended Solids	50mg/L	150mg/L	30mg/L/100	0mg/L/30mg	/L	4.5mg/L
Total Nitrogen			4mg/L	40mg/L		4mg/L
Total Phosphorus			1mg/L	10mg/L		1mg/L
pH		Not required	6-8.5	6-9	6-9	7-8
Fecal Coliforms	250coli/100mL MPN	200coli/100mL	150c oli/100mL	2 CFU/mL (200coli/100mL)	20coli/100mL MPN	10coli/100mL

New market drivers

Regulatory requirements

- USCG/IMO Regulations for the quality of black water discharges.
- USCG/EPA indications that grey water discharges will be regulated and monitored.
- NATO navy strategy for environmentally sound warships.
- ndication that discharge consents for offshore platforms will be aligned with marine standards.

Customer requirements

- Meet the likely regulatory requirements for both new and existing installations.
- Maintain an acceptable public image.
- Minimisation of size and weight. Lowest possible total cost of ownership.
- Biosolids dewatering.
- Nutrient removal

OUR PRODUCT RANGE

Principles of operation

Wastewater collected in the ship's Equalizing tanks (Black water, Galley water, Food waste water, Accom grey water, Laundry water) is pumped to an automatic screen press. Sanitary grey water is collected into buffer tanks and fed to the same automatic screen press. Each MBR includes SBR stages, contained within a single process tank unit. SBR stages are fitted with aerators fed from duty and standby blowers. Wastewater passes through the screen press into the first stage SBR where the active biomass degrades organic material. The active biomass is pumped through an interstage filter which returns particulate and fibrous material to the screen press. The filtered biomass is transferred by duty and standby pumps into the second micro-filtration units, free of any fibers which could cause blockages in the membrane modules. Clean permeate is taken from the membrane modules through flow control valves and flow meters, allowing individual monitoring of each membrane module. Permeate is collected from all membrane modules into a tank and pumped for discharge by duty and standby pumps. Isolating valves are provided throughout the system to enable maintenance of pumps, membrane modules and other components without shutdown of the plant. The system is automated.

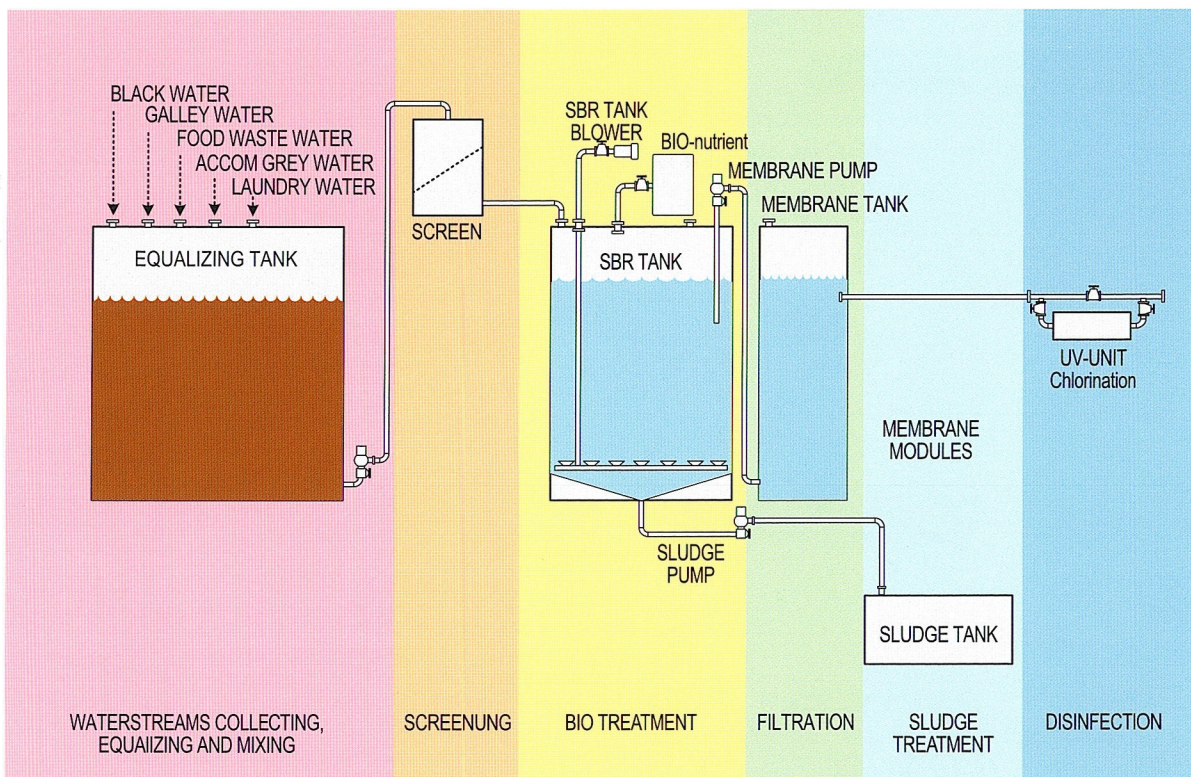

TECHNICAL INFORMATION(EXTERNAL STRUCTURE)

PLAN VIEW

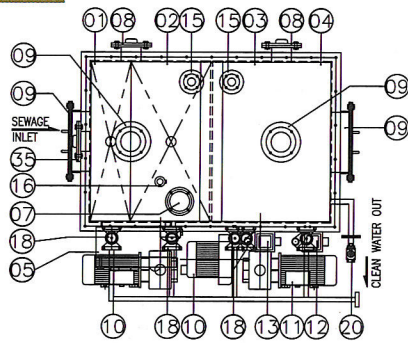

ELEVATION VIEW

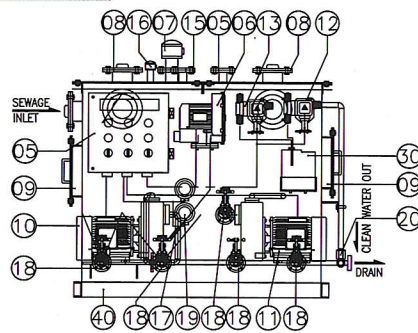

SYMBOL LIST

NO	DESCRIPTION	Q'TY
01	pre-treatment tank	1
02	bio-reactor chamber	1
03	filter out the impurities	1
04	chemical (disinfection) tank	1
05	control panel	1
06	aration blower	1
07	level sensor (high & low)	1
08	sight glass	1
09	manhole	2
10	sludge discharge pump	1
11	clean water discharge pump	1
12	chemical pump	1
13	bacillus inlet pump	1
15	air vent	2
16	high level sensor (emergency)	1
17	air nozzle	1
18	drain globe valve	1
19	return globe valve	1
20	discharge solenoid valve	1
30	chemical tank	1
35	inlet pipe	1
40	common bed	1

Sizing, design

The Han young system was developed as a modular system of four basic sizes for purification of waste water from 10, 35, 100 and 125 people. However we are ready to produce individual solutions for any other request. The bioreactor is produced from stainless steel AISI 316Ti as standard. The bioreactor from other materials is as well possible after a consultation. The Han young Marine units are equipped by electric components 400 W 460 volts, 50 or 60 Hz.

PLAN VIEW

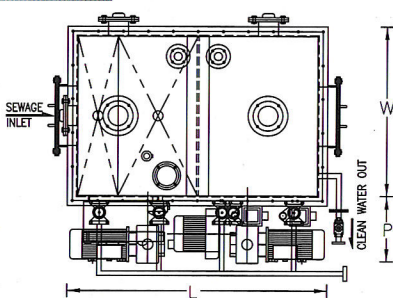

ELEVATION VIEW

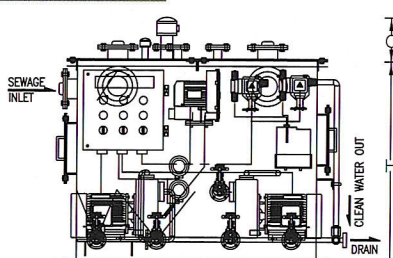

SPECIFICATIONS

MODEL	HYSTM -10	HYSTM -15	HYSTM -25	HYSTM -35	HYSTM -45	HYSTM -60	HYSTM -80	HYSTM -100	HYSTM -125
PERSONS	10	15	25	35	55	60	80	100	125
CAPACITY 1/DAY	1850	2775	4625	6475	10175	11100	14800	18500	23125
W (mm)	850	860	940	1050	1150	1360	1520	1680	1890
L (mm)	1500	1580	1680	1680	2150	2300	2300	2400	2680
H (mm)	1000	1125	1580	1650	1990	2000	2300	2300	2300
O (mm)	300	300	300	300	300	300	300	300	300
P (mm)	500	500	500	500	500	600	600	600	600
TOTAL WEIGHT(kg)	DRY 630	680	890	920	1180	1200	1400	1700	1950
	OPERATION 1010	1050	2876	4430	6030	7200	7800	8100	8750

DISCHARGE PUMP

MODEL	HYSTM -10	HYSTM -15	HYSTM -25	HYSTM -35	HYSTM -45	HYSTM -60	HYSTM -80	HYSTM -100	HYSTM -125
CAPACITY (m ³ /hr)	8	8	8	8	8	8	8	8	8
TOTAL HEAD (m)	20	20	20	20	30	30	30	30	30
MOTOR (kW)	1.0	1.0	1.0	1.5	1.5	1.5	1.5	1.5	1.5
POWER SOURCE	AC220/380/440V, 3ø, 50/60Hz								

BLOWER

MODEL	HYSTM -10	HYSTM -15	HYSTM -25	HYSTM -35	HYSTM -45	HYSTM -60	HYSTM -80	HYSTM -100	HYSTM -125
CAPACITY (m ³ /hr)	90	90	90	90	90	180	180	180	180
PRESSURE (kgf/cm)	1.3	1.3	1.3	1.3	1.3	1.8	1.8	1.8	1.8
MOTOR (kW)	0.5	0.5	0.5	0.5	0.5	0.75	0.75	0.75	0.75
POWER SOURCE	AC220/380/440V, 3ø, 50/60Hz								

 **OUR PRODUCT RANGE**

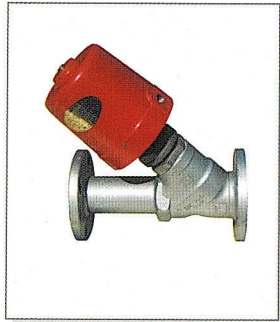

2/3 Pneumatic Cylinder valve
(PT 3/8" ~1")



2/3 Cylinder valve
(5K(10K) -15A~65A)



Electric solenoid valve
(PT 3/8" ~2")



Safety & Relief valve
(PT 1/2" ~3")

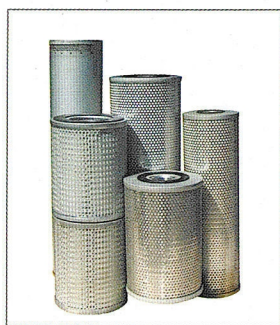

Coalescer & NF filter for
15ppm Bilge Separator



Electric Heater
Device

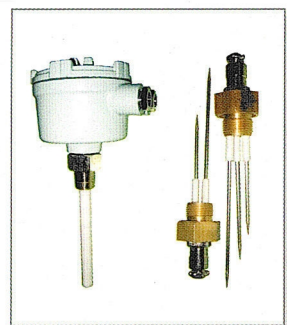

Level Sensor

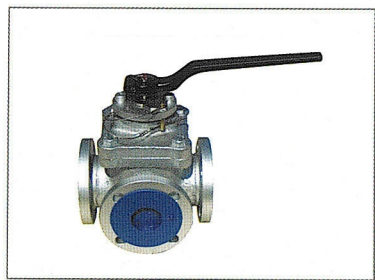

Recirculating
Facilities Manual Valve
(5K-15A~65A)

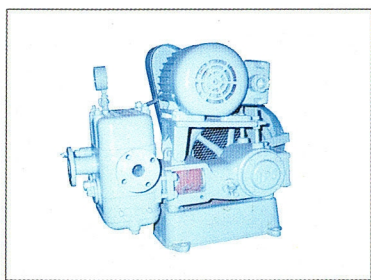

Bilge Piston Pump
Capacity
(0.15~30 m³/h)

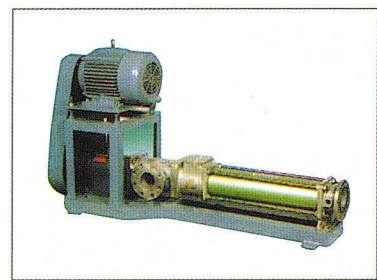

Sludge Mono Pump
Capacity
(1.0~30 m³/h)

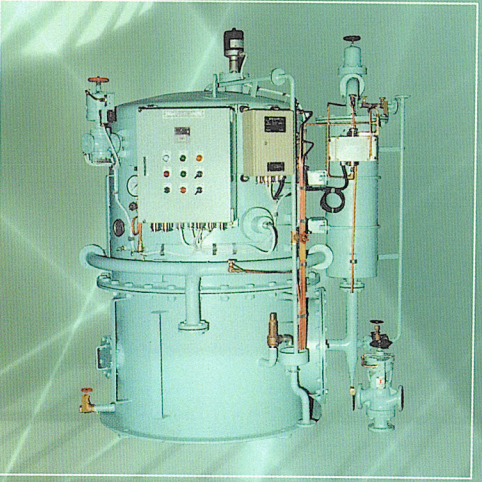
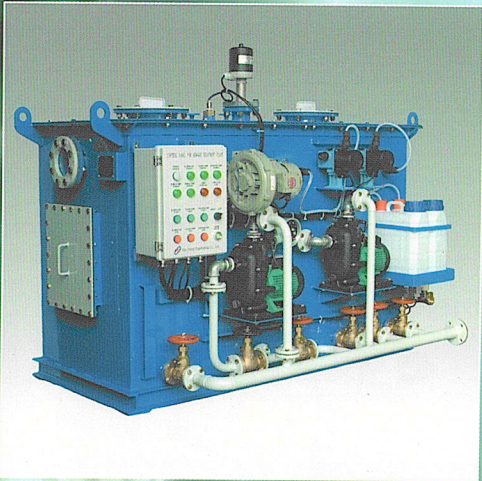

HAN YOUNG ENGINEERING CO., LTD.

HEAD OFFICE : #1009, BYUNGDONG-LI, HANLIM MYUN, KIMHAE,
 & FACTORY KYONG-NAM, 621-873 KOREA.
 TEL. +82-55-345-2933 FAX. +82-55-345-1684
 E-mail:hyows@unitel.co.kr